

INSERTS



High Efficiency Motor



GCX 53 SD
Cod. **02030308** EAN **8422248103572**



- Touch Control Panel** with automatic shut-down timer and cleaning filters indicator
- 4 extraction levels, 3 + 1 **TURBO**
- 1st speed silent mode**
- Extraction power (according to UNE/EN 61591): **750m³/h** - 340m³/h
- Sound power (Reg.(EU) n°65/2014): 50dB(A)**, maximum: 65dB(A)
- BT3 motor. Extra silent. Maximum energy consumption **280W**
- High efficiency strip led lighting**
- Easy-to-install system
- Dishwasher-washable filters
- Stainless steel finishing and grey glass
- Max. Pressure: 470 Pa
- 150/125 mm outlet diameter
- Energy Class: A**

► **Accessories (not included)**

Active charcoal filterCod. 02859398 / EAN 8422248075497.....
Check valveCod. 02832004 / EAN 8422248480499

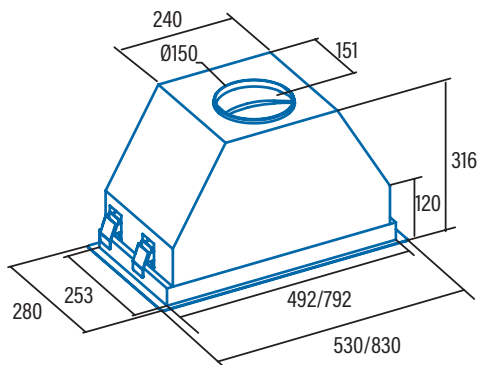

Code	02030308
EAN	8422248103572
Model	GCX 53 SD
Type	Canopy
Product fiche according to directives EU65/2014 - EN61591, EN60704-2-13, EN50564	
AEC (Annual Energy consumption) (kWh/annum)	56,1
EEL class (Energy Efficiency Class)	A
FDE (Fluid Dynamic Efficiency)	30,2
FDE class (Fluid Dynamic Efficiency Class)	A
LE (Lighting Efficiency) (lux/W)	26
LE class (Lighting Efficiency Class)	B
GFE (Grease Filtering Efficiency)	91,2
GFE Class (Grease Filtering Efficiency class)	B
Air flow at minimum speed (m3/h)	340
Air flow at maximum speed (m3/h)	600
Air flow at intensive speed (TURBO) (m3/h)	750
Sound Power Level at minimum speed (dB)	50
Sound Power Level at maximum speed (dB)	65
Sound Power Level at intensive speed (TURBO) (dB)	67
Po (Power Consumption in off mode) (W)	0,3
Ps (Power Consumption in standby) (W)	0
Integration directive EU 66/2014	
f (Time Increase Factor)	0,9
EEL (Energy Efficiency Index)	54,4
QBEP (Flow Rate at Best Efficiency Point) (m3/h)	429,4
PBEP (Static Pressure Difference at Best Efficiency Point) (Pa)	405
WBEP (Electric Power Input at Best Efficiency Point) (W)	159,8
WL (Nominal Power Consumption of Lighting system) (W)	7
EMIDDLE (Average Illumination of Lighting system on Cooking surface) (lux)	170
External Dimensions	
Width (mm)	530
Depth (mm)	280Z
Total max height(mm)	316
Total min height(mm)	316
Outlet Diameter (mm)	150/125
Characteristics	
Motor	BT3
Extraction Levels	3+1
Motor Maximum Power Consumption	280
Maximum Pressure	450
Intensive Speed (TURBO) Pressure	470
Control Type	TC4i
Automatic shut-down timer	√
Electronic Filter Saturation Indicator	√
Filter Type	Metallic
Anti-grease Filter Number	2
Inner Shield	-
Lighting	
Light Type	SSLED
Adjustable Intensity Lighting	√
N° of Lamps	1
Installation	
Minimum height distance to a electric worktop hob (mm)	550
Minimum height distance to a gas worktop hob (mm)	650
Installation with Outlet tube to the exterior / Recirculating	BOTH
Easy Installation System	√
Electric Connection	
Total Rush Power (W)	285
Rated Voltage (V)	220-240
Network Frequency (Hz)	50
Electrical Insulation Class	CLASS II
Plug	EU - 2 pins
Accessories	
Upper Decorative tube Extension	-
White Decorative Tube	-
Black Decorative Tube	-
Island Tube Enhancer	-
Check Valve	02832004
MAX PRO Metal Filter	-
Metal Filter	65300310
DUAL Filter (metal + active charcoal)	-
Active Charcoal Filter	02859392
Noiseless Flexible Duct	02893002